

Vehicle safe electrical grounding based on **key Interlocking**

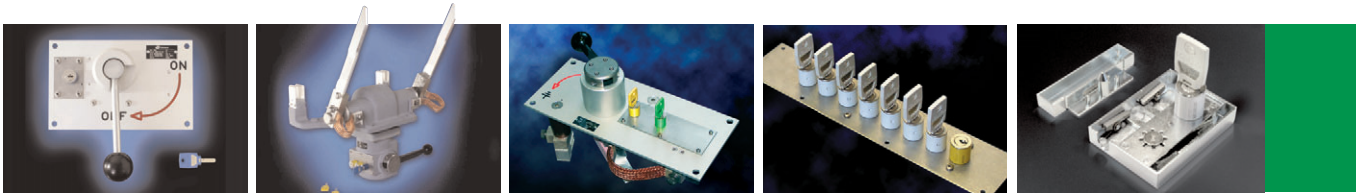

Safety based on key interlocking

To guarantee the electrical grounding of the vehicle, with respect of highest and most reliable standards for the safety of maintenance personnel, Sécheron offers a system based on key interlocking.

Starting from the pantograph (capturing the current at the catenary), down to the propulsion converter (powering the traction motors), there are several security devices that must be installed on the roof and inside the vehicle in order to isolate and ground the equipment linked to the high voltage. The philosophy is based on a simple step by step principle that enables the manipulation of a safety device only once the previous one in the traction chain has been operated and locked in the grounding position. This principle is achieved through a cascade of security keys and associated locks as shown in the following diagrams.

Example: Electrical multiple unit

BSV
Pantograph
interlocking box

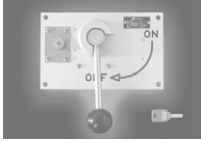

BTE 15/25.04
Roof earthing switch

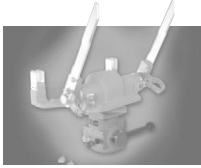

BTE 03.04
Indoor earthing switch

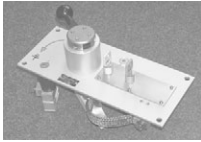

**KEY
MULTIPLIER/
HOLDER**



**DOORS
LOCKS**

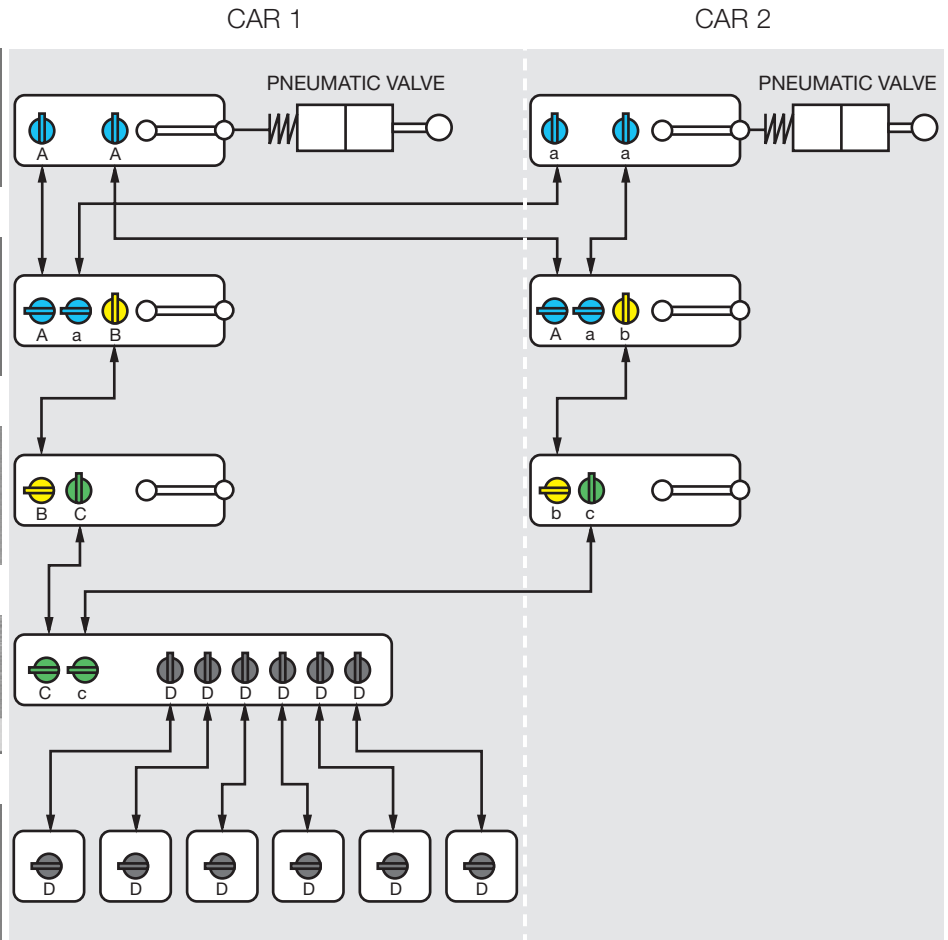

Example: Electrical multiple units

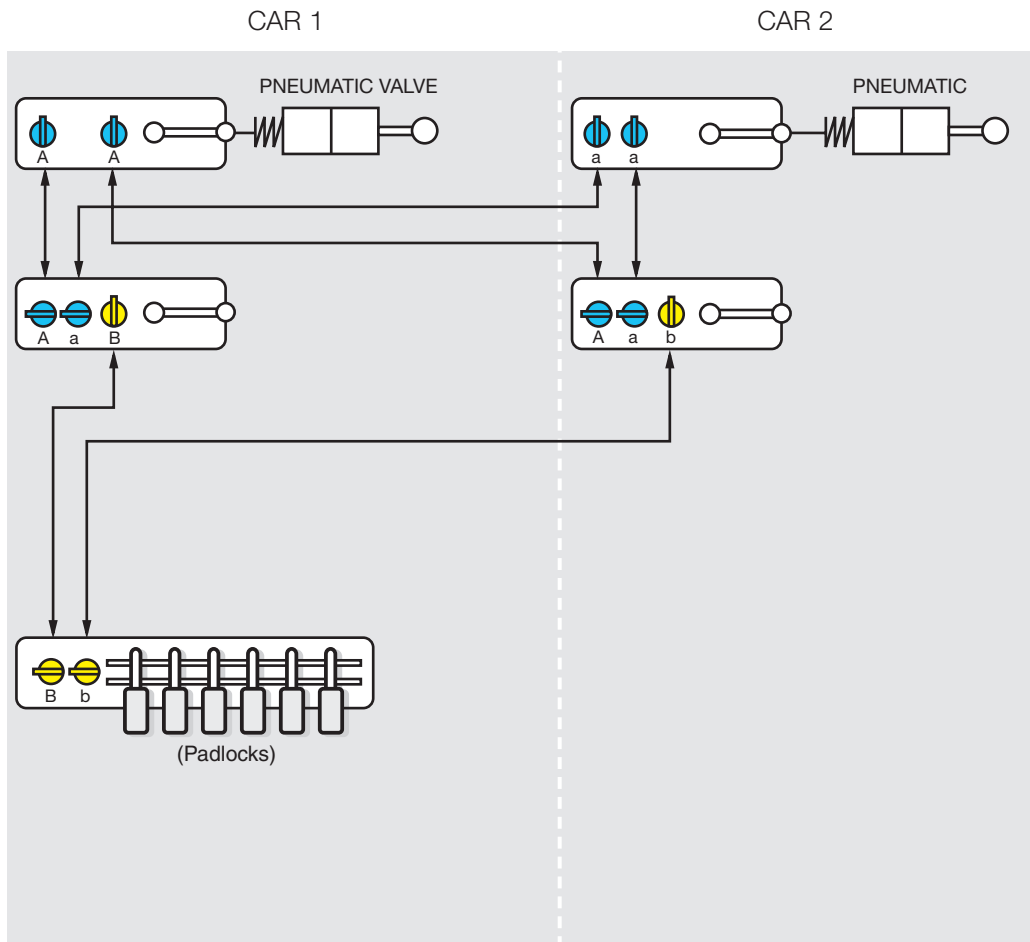
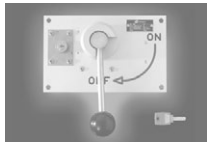

Color codes

- A Blue
- B Yellow
- C Green
- D Black
- E White

Example: AC Locomotive

Example: DC Locomotive

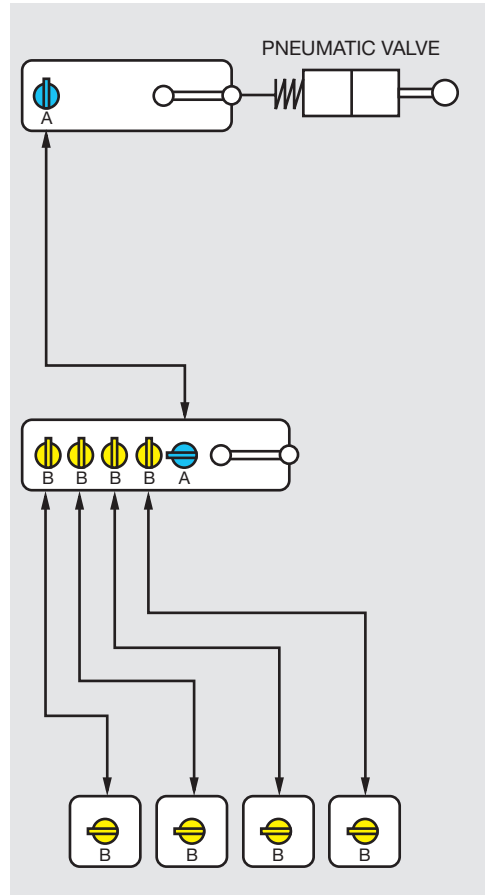
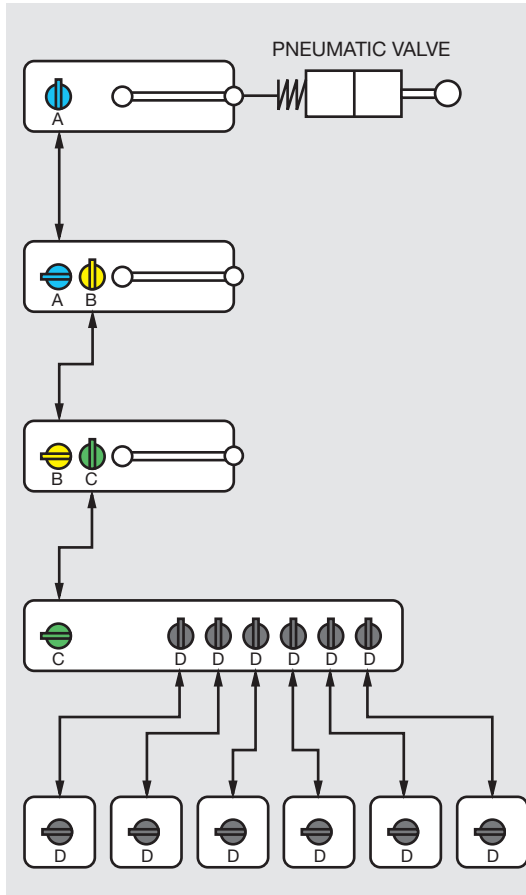
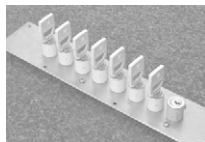

Color codes

- A Blue
- B Yellow
- C Green
- D Black
- E White

For other requests please contact Sécheron

SG480329BEN_A00-10.03



Sécheron SA
Rue du Pré-Bouvier 25
1217 Meyrin - Geneva
CH-Switzerland

Tel: +41 (0)22 739 41 11
Fax: +41 (0)22 739 48 11
info@secheron.com
www.secheron.com

This document is not contractual and contains information corresponding to the level of technology at the date of printing. Sécheron reserves the right to modify and/or improve the product, whose characteristics are described in these documents, as required by new technology at any time. It is the purchaser's responsibility to inform himself, no matter what the circumstances, of the product's maintenance conditions and requirements. Sécheron reserves all rights, especially those arising from our "General Delivery Conditions".