

COMPONENTS

# XMS DISCONNECTOR



The **XMS disconnector** is designed to connect and isolate electrical circuits in traction vehicles, and it offers to our customers a complementary solution to the use of Sécheron's contactors for rated thermal currents up to 1500 A and rated voltages up to 4000 V.

The various applications suitable to this device include the selection of the adapted voltage on the secondary

winding of the transformer for dual voltage AC vehicles, as well as the isolation of the main traction inverters for EMUs or Metros.

Fitting the XMS with clever technical solutions has enabled Sécheron to develop a device with a high level of performance, combined with the highest reliability.

## Main features

- Operational voltage rated up to 4000 V (AC and DC)
- Rated thermal current 800 A and 1500 A
- Multi-poles versions up to 3 poles
- Electromagnetic closing
- Short opening and closing times
- Identical opening and closing electrical pulses
- High short time withstand current value
- Horizontal and vertical mounting positions
- Low power consumption
- Small clearance distance requirements
- Reduced weight and dimensions
- Complies with standards IEC 60077-1, 60077-2, IEC 61373 (category 1 class B)
- CE marking
- High overvoltage category, OV3
- High resistance to pollution (degree PD3)

## Designation code standard version

### Type designation

Description	Designation	Code	
Disconnecter	XMS	XMS	<b>XMS 40 08 0 1 0 110 2 0 A 0 0</b>
Rated operational voltage	4000 V	40	
Conventional free air thermal current	800 A	08	
	1500 A	15	
Height	Standard (342 mm)	0	
Number of poles	1 pole	1	
	2 poles	2	
	3 poles	3	
Mechanical link between poles	Yes	L	
	No	0	
Control voltage	24 Vdc	024	
	36 Vdc	036	
	48 Vdc	048	
	72 Vdc	072	
	84 Vdc	084	
	110 Vdc	110	
Auxiliary contacts *	1X + 1Y	2	
Low Voltage interface	Screw terminal	0	
Angles position	4 bottom - outwards	A	
	4 bottom - inwards	B	
Spare digit		0	
Spare digit		0	

\* X and Y: switches with 1a (NO) + 1b (NC) contacts each - The difference between Y and Z refers to their position inside the XMS

## Technical data

	Symbol	Unit	XMS 40.08	XMS 40.15
<b>MAIN CIRCUIT</b>				
Rated operational current	$I_e$	[A]	800	1500
Conventional free air thermal current	$I_{th}$	[A]	800	1500
Rated operational voltage	$U_e$	[Vdc] [Vac]	4000 4000	4000 4000
Rated insulation voltage	$U_i$	[V]	(16 <sup>2/3</sup> /3, 50, 60) * 4000 (OV3) 5000 (OV2)	(16 <sup>2/3</sup> /3, 50, 60) * 4000 (OV3) 5000 (OV2)
Maximum breaking capacity under 4000 Volts	$I_c$	[A]	100 mA	100 mA
Maximum making capacity under 100 Volts	$I_f$	[A]	10 A	10 A
Rated short time withstand current ( $T_{amb} = 40^\circ\text{C}$ )	$I_{cw}$	[kA]	60	60
Short time current duration	$t$	[ms]	100	100
Dielectric test voltage (50 Hz, 1 min)				
- Across main contacts (open)	$U_{50}$	[kV]	12	12
- Main circuit (closed) to earth	$U_{50}$	[kV]	12	12
- LV circuit to earth	$U_{50}$	[kV]	1.5	1.5

\* for other frequency contact Sécheron

## CONTROL CIRCUIT

Nominal voltage per pole	$U_n$	[Vdc]	24,36,48,72,84,110	
Closing and opening power at $U_n$ and $T_{amb} = 20^\circ\text{C}$	1 pole	$P_c/t$	[W]/[s]	365 / 0.5
	2 poles	$P_c/t$	[W]/[s]	730 / 0.5
	3 poles	$P_c/t$	[W]/[s]	1095 / 0.5
Nominal holding power	$P_c$	[W]	0	
Mechanical opening time (not included pulse time) at $U_n$ and $T_{amb} = +20^\circ\text{C}$	$t_o$	[ms]	< 100	
Mechanical closing time at $U_n$ and $T_{amb} = +20^\circ\text{C}$	$t_c$	[ms]	< 100	

## AUXILIARY CONTACTS CIRCUIT

Rated voltage (potential free contacts)	[Vdc]	24 to 110	24 to 110
Rated current	[A]	10	10
Maximum breaking current			
- Ohmic load at 110 Vdc	[A]	1	1
- Inductive load $\tau = 15$ ms at 110 Vdc	[A]	0.3	0.3
Minimum let through current at 24 Vdc (1)	[mA]	10	10

(1) For a dry and clean environment

## OPERATING CONDITIONS

Ambient temperature	$T_{amb}$	[°C]	-40 to +70	-40 to +70
Minimum mechanical durability	operations		125'000	125'000

## OPENING AND CLOSING SEQUENCES

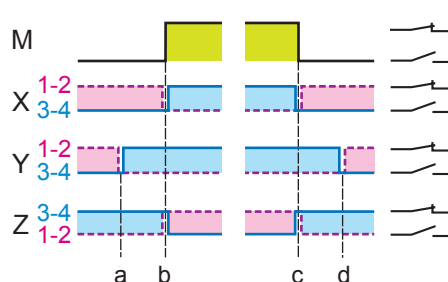

- M. Main contact
- X. X auxiliary switch configuration (standard)
- Y. Y auxiliary switch configuration (standard)
- Z. Z auxiliary switch configuration (option)
- a. Early switching of auxiliary contacts
- b. Normal switching of auxiliary contacts
- c. Normal switching of auxiliary contacts
- d. Late switching of auxiliary contacts

## Main dimensions (standard version)

### Standard height version

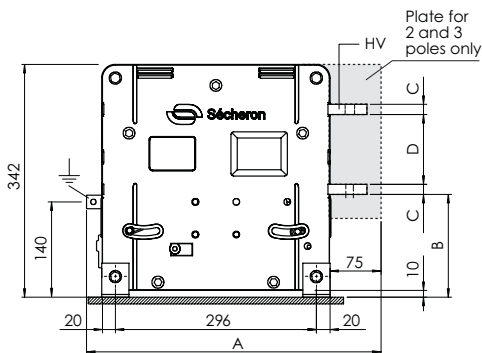

### 1 pole

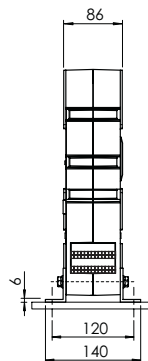

### 2 poles

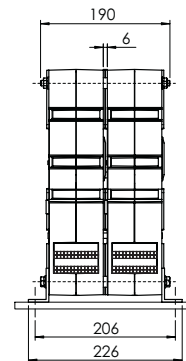

### 3 poles

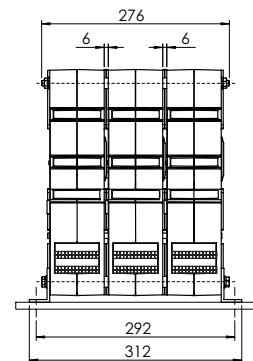

	Weight per pole [kg]	A [mm]			B [mm]	C [mm]	D [mm]
		1 pole	2 poles	3 poles			
XMS 40.08	10	392	433	433	146	20	100
XMS 40.15	13	412	433	433	151	15	102.5

## Options (Subject to additional costs)

### Type designation

Height

Auxiliary contacts<sup>(1)</sup>

Low voltage interface

Angles position

Small (293 mm)

2X

2Y

2X+1Z

1X+1Y+1Z

2Y+1Z

18 poles AMP connector<sup>(2)</sup>

No angles

**XMS 40 08 S 1 0 110 4 1 D 0 0**

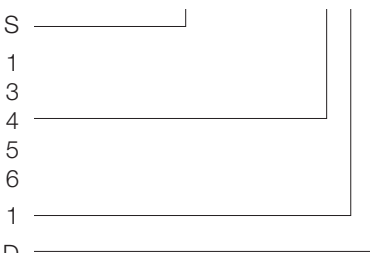

(1) X, Y, Z: switches with 1a (NO) + 1b (NC) contacts each - The difference between X, Y and Z refers to their position inside the XMS

(2) The mobile connector is not included in our scope

### Small height version

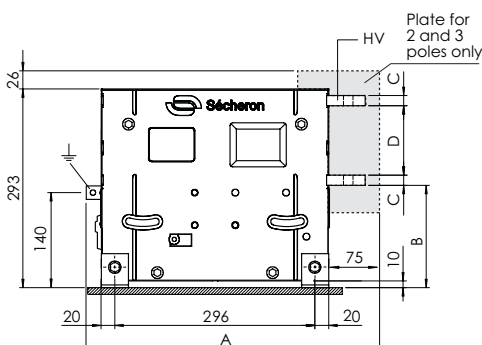

### 1 pole

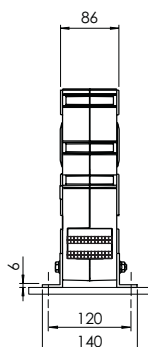

### 2 poles

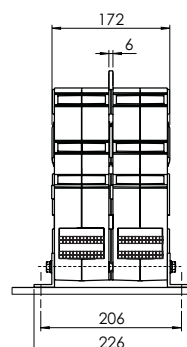

### 3 poles

