

Wheel Flange Lubricator
Type Lausanne



INTRODUCTION

The problems of wear due to friction on rolling stock wheel flanges and rails are well known. Fortunately the maintenance costs of the rails and wheels can be substantially reduced by means of WHEEL FLANGE LUBRICATORS.

For many years, SÉCHERON, Geneva, have been manufacturing and selling WHEEL FLANGE LUBRICATORS intended for Railway Vehicles all over the world. Our extensive experience in this field, enables us to offer advice and specific solutions adapted to each vehicle and corresponding to each network.

APPLICATION

The wheel flange lubricator SÉCHERON can be applied on:

- main-line locomotives, shunting and industrial locomotives;
- motor-coaches and train-sets;
- motor-coaches and locomotives for rack-railways (lubrication of the rack pinion);
- underground railways;
- tramways.

REQUIREMENTS

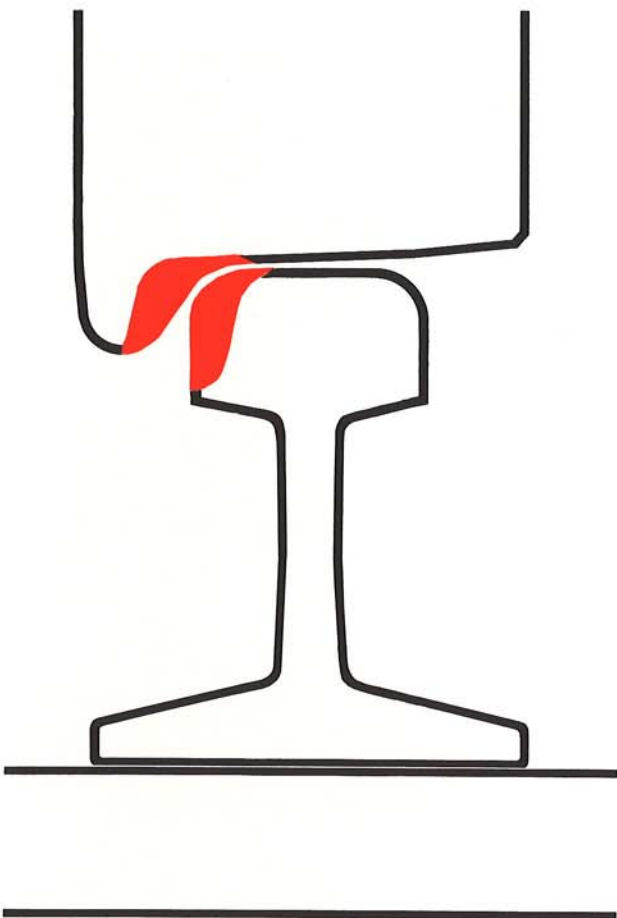

- substantial reduction in the wear of wheel flanges and rails;
- improved adhesion due to reduced friction (less danger of derailment);
- reduction of squealing due to friction between wheel and rail around curves;
- reduction of train resistance to rolling;
- availability of different lubricants which can be used in a variety of conditions (extreme temperatures, biodegradable liquids, etc.);
- simple installation and low maintenance costs;
- reliability, regardless of the working and climatic conditions;
- a favourable ratio between the capital investment and a reduction of costs due to wear of rails and wheels;
- flexibility (lubrication quantity and lubrication interval can be determined depending on the nature of the working and the type of vehicle);
- minimal soiling of rolling stock (lower part of the vehicle chassis).

Only LUBRICATION EQUIPMENT WHICH IS INSTALLED ON VEHICLES can meet all these requirements. The WHEEL FLANGE LUBRICATOR SÉCHERON, Lausanne type, is used all over the world on thousands of vehicles in the most severe operating and environmental conditions.

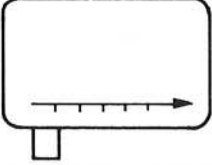
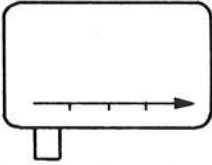
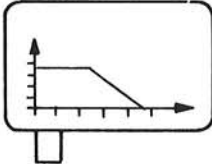
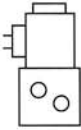
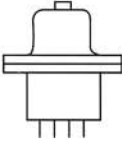
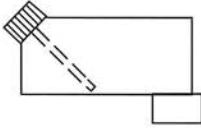

TECHNICAL DATA

Electronic control unit. The lubrication commands which are issued are determined by the criterion indicated.

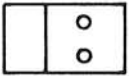
Type L Criterion: the <i>distance</i> covered		$U_n = 24 \text{ to } 120 \text{ Vdc}$ + 25% - 30% Adjustment, standard values: 150-300-450 m
Type T Criterion: the <i>time</i> of the distance covered		$U_n = 24 \text{ to } 120 \text{ Vdc}$ + 25% - 30% Adjustment, standard values: 10-15-20-30-40 s
Type V Criterion: the <i>distance</i> covered and <i>speed</i>		$U_n = 24 \text{ to } 120 \text{ Vdc}$ + 25% - 30% Adjustment, standard values: - distance covered: 50-75-100-150-200-300-400 m - lubrication decreasing: 30-40-50-60-70 km/h - lubrication suppression: 70-90-110-140-160-180 km/h
Electro-pneumatic valve, direct control 3/2		$U_n = 24 \text{ to } 120 \text{ Vdc}$ + 25% - 30% $P_n = 6 \text{ bar}$; P min. = 3 bar; P max. = 12 bar electric connections: Faston type air connections: G 1/4"
Distributor		- 4 pumps - adjustment of oil quantity 10-40 mm ³ per pump - 1 air connection G 3/8" - 4 oil connections G 1/4"
Tank (3 types, see overall dimensions)		- capacity 7 litres (other size on request)
Nozzle		- air connection 1/8" - oil connection 1/8"
Differential cylinder		- to be used only when an absolutely tight system is required and when the installation does not give perfect tightness by other means. - Air connection 1/8" - Oil connection 1/8"

ASSORTMENT AND CHOICE

Main line locomotives and Shunting locomotives of medium and high power	Industrial locomotives and Shunting locomotives of low power	Unidirectional underground railway	Bidirectional underground railway	Unidirectional tramway	Bidirectional tramway	Motor-coach	Reversible train set	Rack railway vehicle	
①	①					①	②	①	Type L
		①	①	①	①				Type T
①	①	①	①	①	①	①	②	②	Type V
2	1	1	2	1	2	2	2	2	Tank and Distributor
8	4	4	8	4	8	8	8	8	Nozzle
				④	⑧				Differential cylinder

○ Choice according to application.

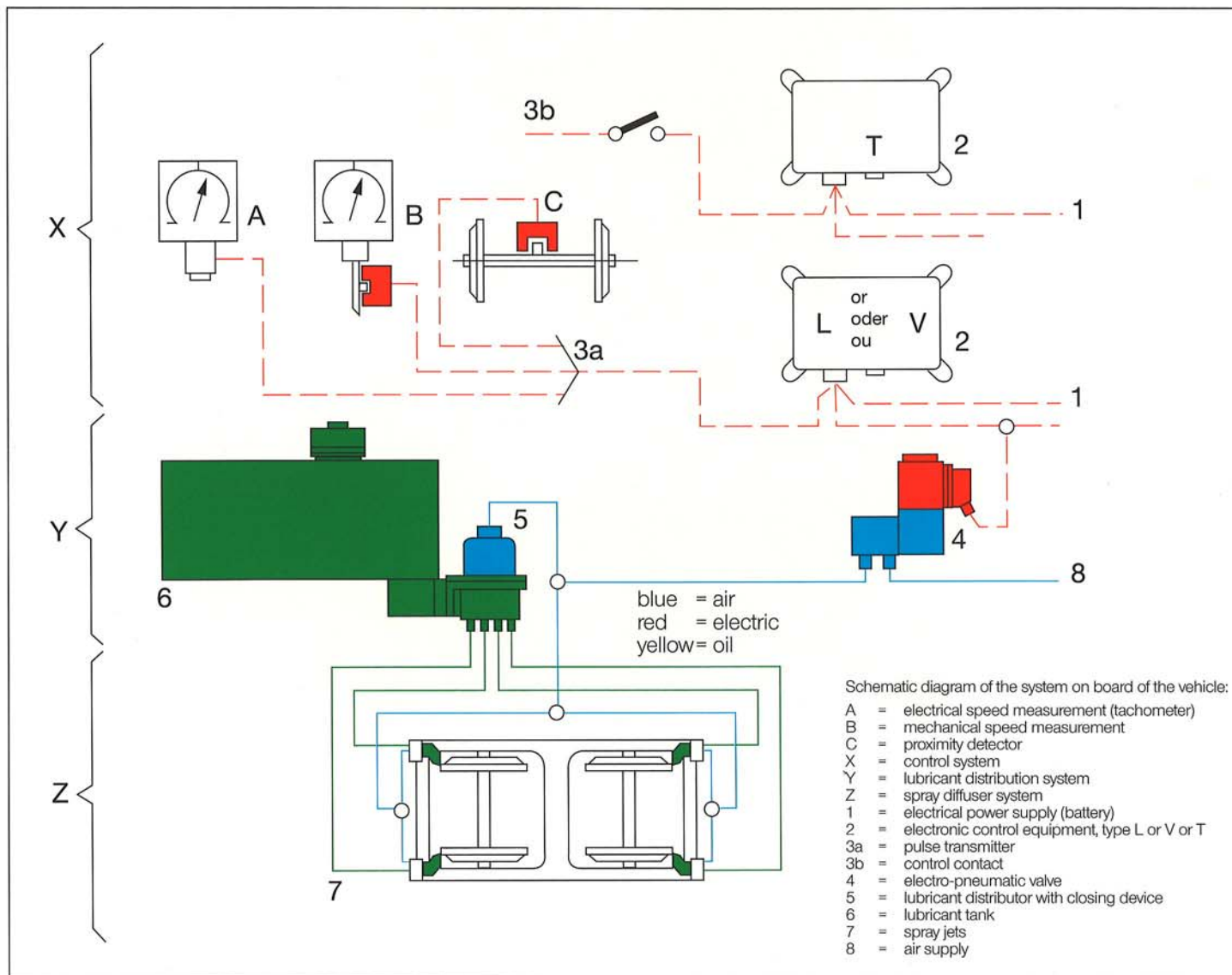

OPERATING DESCRIPTION

Compressed air and electrical control current are required for operation.

The wheel flange lubricator SÉCHERON sprays a controlled quantity of special oil on the flange at fixed intervals as a function of the electronic control criterion [f(m), f(s) or f(m and v)].

The operation is automatic and requires no monitoring by the driver.

The vehicle starts running:

- the impulses given by A, B or C (3 a) necessary to control the types "L" and "V", are memorized.

- the control contact (3 b) necessary for the electronic control unit type T, closes and releases the counting system.

When the set distance has been covered or the set time has elapsed, the output relay of the electronic control releases voltage (1) to the valve(s). The valve(s) opens, producing an air flow, actuating the distribution piston of the distributor (5), which transmits a controlled quantity of oil to the nozzles by means of 4 pumps. The oil is sprayed over the flanges by air directed in parallel through the nozzles.

(The system does not work if the vehicle is at a standstill).

Lubrication mechanism (1)

Consumption of lubricant and air

This consumption depends on various factors such as:

- the type of vehicle and its equipment (number of nozzles);
- the choice of the lubricant quantity per impulse;
- the lubrication interval (choice of the electronic control and its adjustment);
- the average speed of the vehicle.

Example based on the following assumptions:

- equipment with 8 nozzles
- average speed of the vehicle 55 km/h
- lubrication interval 300 m or 20 s resting time
- lubricant per impulse and nozzle 30 mm³
- average supply pressure = 6 bar

Lubricant consumption: approx. 67 litres/100,000 km.

Air consumption: approx. 140 litres/minute.

(On request, we will calculate the values for your particular requirements).

Lubricant

Required lubricant properties:

- high adhesive power (resistance against the centrifugal force);
 - resistance against high pressures;
 - high inflammability point;
 - fluidity at low temperatures;
 - no upward flow towards the rail head (capillary action).
- (See our separate recommendations, stated according to the operation criteria).

METHOD OF INSTALLATION

For: (2)

- industrial and shunting locomotives of low power
- unidirectional underground railway
- tramway

For: (3)

- main-line locomotives and shunting locomotives of medium and high power
- bidirectional underground railway
- tramway
- motor-coach
- reversible train sets
- for rack-railway vehicles, pantograph and industrial applications on request
- the distributor tank block and the nozzles are mounted on the bogie and linked by pipes. The major advantage of this method of assembly is that the oil circuit always remains closed (no drying of the lubricant and no separation of the conduits when replacing the bogie).
- the valve is mounted on the bogie or under the body, but the air conduit linking the valve and the distributor must in no case exceed 5 m.
- the electronic control unit must be located inside the vehicle.
- different methods of installation are possible and require special study.

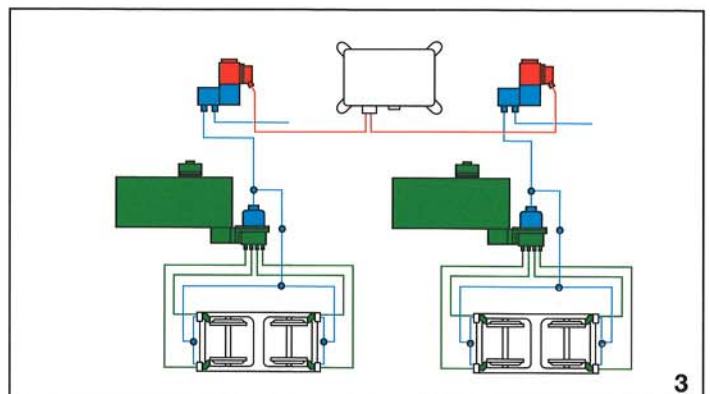
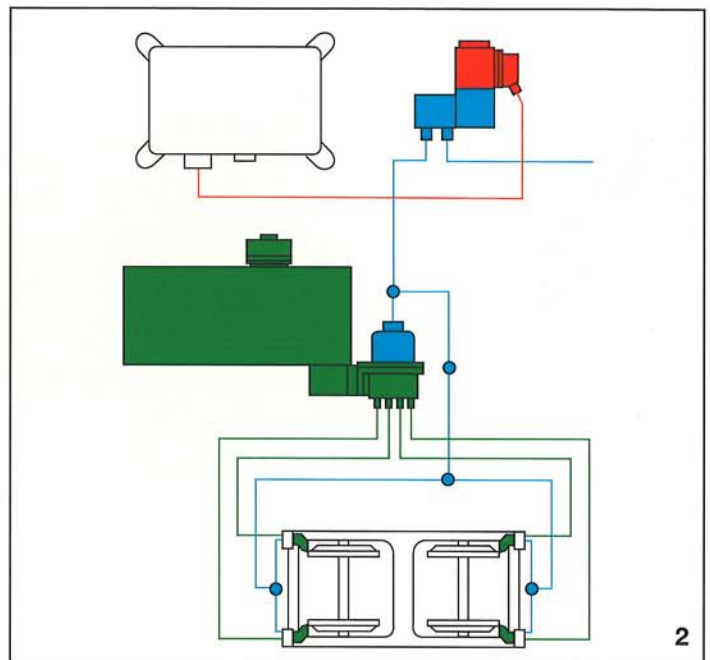
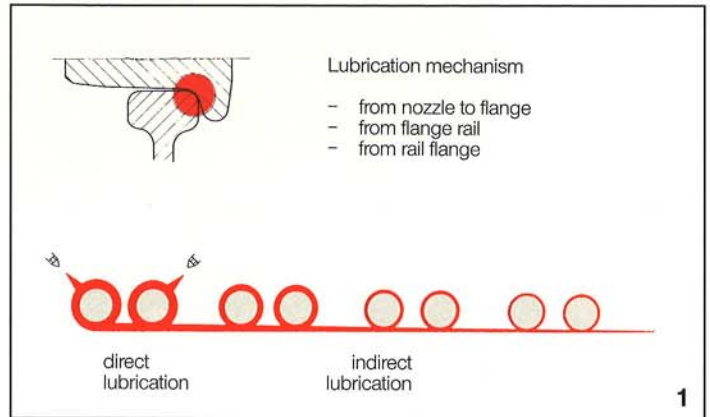

ADVANTAGES AND RESULTS

The wheel flange lubricator has the following DIRECT ADVANTAGES:

Reduction of:

- the wear of the vehicle wheels (flanges)
- the wear and deformity of the rails
- the rolling resistance
- the derailment risk, as the friction coefficient is reduced

Elimination of wheel squealing.

The above will result in the following INDIRECT ADVANTAGES:

Reduction of:

- the costs of reprofiling the axles (wheels) and rails
- the costs of replacement of wornout material
- the costs of immobilizing of the vehicles.

Increase of:

- safety
- passenger comfort.

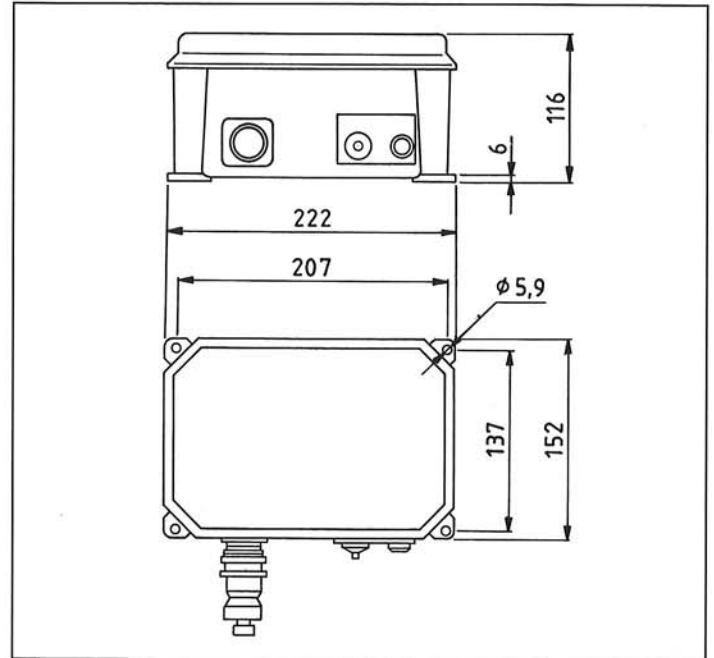

Electronic control unit (L + T + V)

CONTROL, ADJUSTMENT, MAINTENANCE

Equipment operation is controlled by actuating the switch located on the control unit or by actuating the valve(s) EP directly and manually.

After each reprofiling, the nozzles must be adjusted by means of the elliptical holes on their mountings, so that the oiljet is transmitted correctly on the flange.

Maintenance is limited to the following operations:

- Draining the water separator and cleaning of the filter. Both are located in front of the valves EP in the pneumatic circuit.
- Cleaning the inside of the upper part of the distributor approx. every 500,000 km.
- Exterior cleaning of the nozzles as well as checking to ensure the correct oil pulverization with each filling of the tank.
- On each main checking of the vehicle, verify the system (piping). The tank must never be completely empty. The oil level can be easily verified by the gauge plug.

OVERALL DIMENSIONS

- Electronic control unit (L + T + V)
- Valve EP
- Tanks, 3 types
- Distributor
- Nozzle
- Differential cylinder.

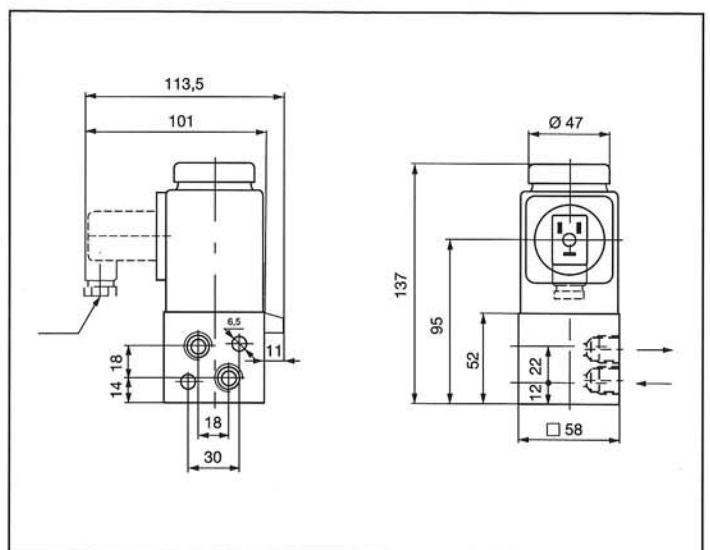

Valve EP

Tank 3 types (with distributor)

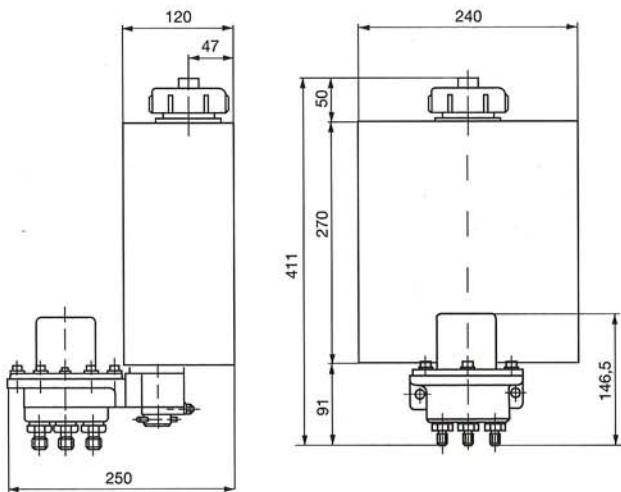
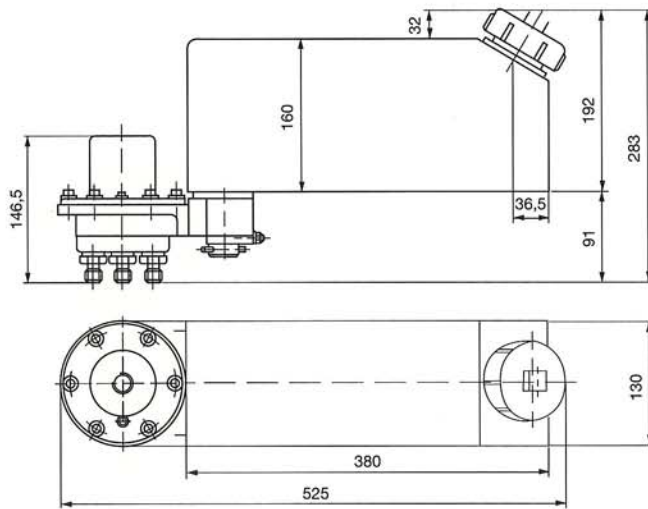
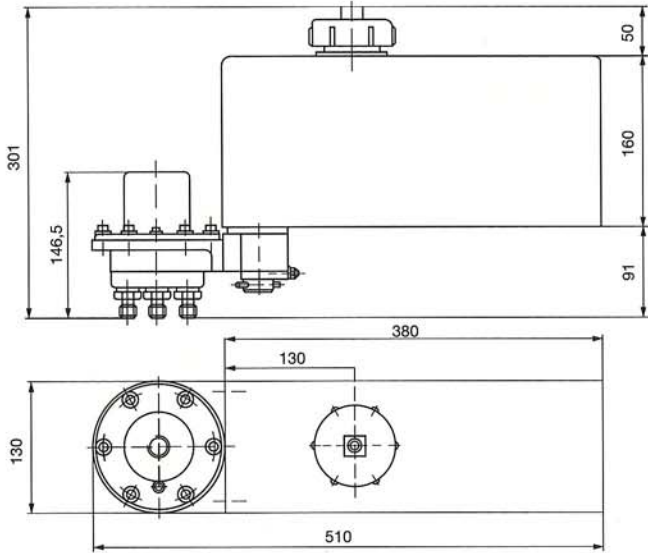

Distributor

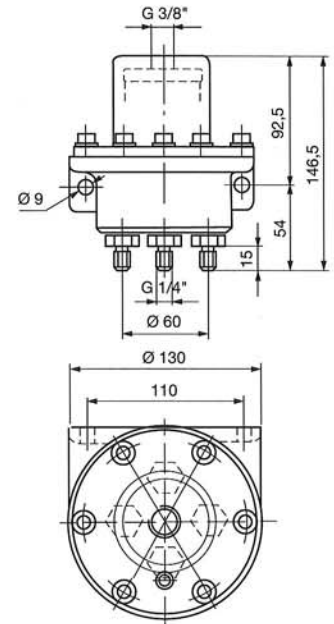

Nozzle

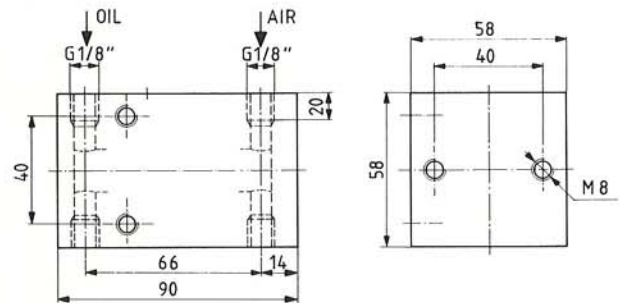
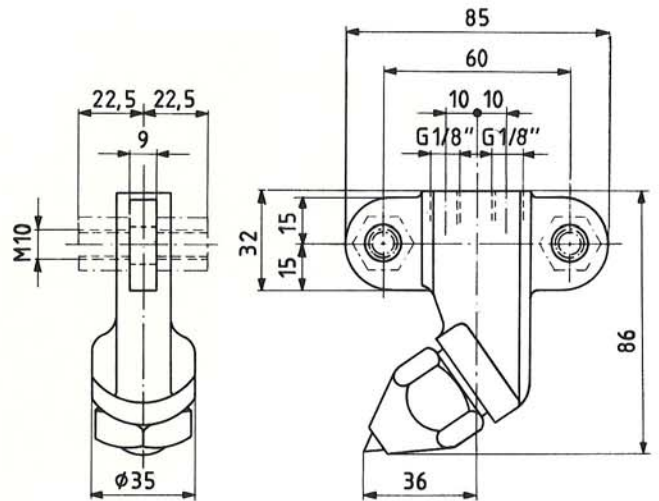

Differential cylinder